

Acom

Advanced Communications System

DIGITAL CONSOLE TECHNOLOGY

COMMAND-AND-CONTROL COMMUNICATIONS FOR YOUR MISSION-CRITICAL ENVIRONMENT

Mission-critical organizations are those that depend on their communications to continue, even if a server, position, network or system fails. Zetron's Acom Advanced Communications System (Acom) is designed to provide the resiliency such organizations require to ensure the integrity and reliability of their communications.

Acom is a fully digital, state-of-the-art switching and multiplexing communications system that has been designed by experts in mission-critical communications. Acom offers exceptional performance and superior network connectivity. In addition, its flexibility supports the cost-effective evolution of your system over time.

Acom is ideally suited to dispatching operations where systems must keep running even if a catastrophic event occurs. Types of dispatching operations in which Acom has been successfully installed worldwide include:

- **Public safety** – Police, fire, ambulance and disaster management
- **Transportation** – Aviation, railway, highway-command headquarters and maritime communication facilities
- **Utilities** – Electrical, water, oil, gas and mining
- **Government and military facilities** – Military and defense command points

ACOM SYSTEM BENEFITS

Fault-tolerant, robust, reliable operations

- System architecture is designed to keep operating even if a fault condition occurs.
- Acom's reliability reduces unscheduled repairs and lowers maintenance costs.

Efficient, intuitive, easy-to-configure user interface (UI)

- UI can be configured to accommodate a range of common business practices and operations.
- UI is easy to learn and operate.
- System resources can be consolidated into a single user interface and customized to suit a particular user or role. This improves productivity and reduces training costs.
- Simple one-touch operation can be used to contact individuals or groups.

Enhanced interoperability

- Provides interoperability for a wide variety of radio and telephone equipment and other communications devices.
- Numerous devices and systems can be accessed simultaneously from a single control point.

Rich set of features

- Extensive feature set supports the needs and requirements of a wide variety of operational scenarios.

Enhanced systems integration

- Allows telephone and radio communications to run on one platform, eliminating the need for multiple systems.

Low-cost evolution and system longevity

- Acom's ability to incorporate new and evolving technologies extends the life of the system and reduces costs.

Scalable platform

- Modular architecture allows your system to grow along with the needs of your communications facility, regardless of the size of the operation.

Customer support

- Various levels of on-call support are available to ensure that you can get the help your system requires if and when you need it.

Options for customization

- Additional functionality can be incorporated into your system to meet your organization's specific operational needs.



ACOM OVERVIEW

Flexible

Acom's end-to-end digital architecture integrates voice (radio and telephone), data, paging and video transmitted over a LAN or a Web browser to provide unmatched flexibility and ease of use. Operating on a local-area or wide-area backbone, a single Acom switch can support large-capacity, region-wide or country-wide dispatch systems.

Highly interoperable with radio

Acom's high degree of interoperability supports communications across a wide spectrum of radio bands and dissimilar communications interfaces, including P25, OpenSky®, iDEN®, TETRA, EDACS®, SMARTNET®, SmartZone®, MPT 1327 and LTR®. This ensures that agencies with diverse radio equipment can communicate.

Full-featured, easy-to-integrate telephony package

Acom offers a feature-rich telephony communications package. This includes functionality that integrates with standard analog subscriber and exchange ports as well as ETSI ISDN and E1 QSig.

It also includes:

- Automatic Call Distribution
- Call Event Applications
- Recorded Voice Announcement
- Interactive Voice Response

Redundant

Acom can be configured for full redundancy with "hot-standby" equipment. This ensures the highest levels of system integrity and reliability that are so crucial in a mission-critical environment. It also makes Acom the ideal solution for integrated communication-and-control operations and consolidated dispatch facilities, as well as backup, remote or mobile-dispatch points. Acom is also ideal for integrating with or replacing legacy communication systems.



Suitable for large or small operations

The size of an Acom system can range from a few dispatchers operating in a fixed or mobile environment to 100+ operators that are centrally located or distributed across multiple communication sites. Communication facilities located in different geographical areas can be networked to provide distributed switching and wide-area control. This improves efficiency and operational effectiveness and provides maximum security and reliability.

Configurable

Acom's Windows®-based consoles offer intuitive, easy-to-use interfaces that can be configured to provide any mission-specific functionality your organization requires.

VoIP-capable

Acom provides the ideal platform to implement communication technologies such as Voice-over-Internet-Protocol (VoIP) and "digital-at-the-desktop" functions.

ACOM CAPABILITIES

- Radio dispatch
- PABX access
- PSTN access
- Autocall routing
- Automatic Call Distribution
- VoIP
- Embedded HTML/PDF browser
- Hotlines, intercom and public address
- Trunked-radio interfaces and protocols
- Network LAN and WAN connections and protocols
- Patching and conferencing
- Paging
- Selective calling (SELCAL)
- Open-data architecture to support third-party developers
- Digital data telemetry
- Control of closed-circuit television (CCTV)
- Web-streaming video for CCTV
- Alarm monitoring
- Channel monitoring
- Voice logging
- Recorded Voice Announcement
- Interactive Voice Response
- Remote control and management

ACOM SYSTEM COMPONENTS



Several basic components form the foundation of the Acom system architecture and contribute to its high system capacity, functionality, configurability and redundancy.

These components are:

- The Acom Line Subrack (ALS)
- The Acom Console Unit (ACU)
- The Acom DS3 Subrack (ADS)

ACOM LINE SUBRACK (ALS)

The Acom Line Subrack (ALS) provides the connection to external field equipment, whether it is radio, telephone, digital I/O or data. Acom has a range of card types that allow it to be matched perfectly to the intended application. The ALS connects the external equipment to the Acom switch through a T1 or E1 link over either a direct wire-line connection or an IP network connection. This gives Acom a variety of sophisticated switching, conferencing, multiplexing and digital signal processing (DSP) capabilities.

The powerful DSP capabilities of the ALS allow it to perform a multitude of audio tone signaling and audio processing functions that enhance the system's audio performance. All incoming audio is converted to a digital signal before it is passed to the switch for audio routing.

ACOM CONSOLE UNIT (ACU)

Each Acom operator position is equipped with a Windows-based workstation and an Acom Console Unit (ACU). The ACU connects the workstation to the Acom switch through a redundant T1 or E1 link over either a direct wire-line connection or an IP network connection. This provides the position with local switching of all operator transmit-and-receive audio.



The ACU is an intelligent switch. It includes daughterboards that provide access to radio and telephone voice channels, data, signaling, and T1 or E1 connections. The ACU also includes sophisticated switching, conferencing, multiplexing and DSP capabilities. Its full-duplex audio gives operators control over how audio is presented through headsets and over external speakers.

The ACU also provides connections to audio devices such as desktop microphones, headsets, handsets, speakers, footswitches, "on-air" indicator lights, long-term voice loggers and Instant Recall Recorders (IRR), such as Acom's built-in Integrator IRR application. This makes the Acom console a highly flexible, modular workstation that can evolve along with your operational environment.

The ACOM DS3 SUBRACK (ADS)

The Acom DS3 Subrack (ADS) provides Acom's high-bandwidth backbone. The operator position's ACU and the ALS are connected through a T1 or E1 link over either a direct wire-line connection or an IP network connection to the Acom switching backbone. The ADS consists of a controller and several dual interface modules that manage the transmission of communications and data between the ACUs and ALSs. Multiple ADS units can be linked together in a self-healing ring architecture that forms the foundation of the Acom system.

ACOM CONSOLE SOFTWARE AND SYSTEM TOOLS



Button-based ACS configuration

The Acom console workstation is the control point through which operators select the radio channels and telephone lines for direct communications, patching, conferencing, signaling, paging and messaging. The Acom Console Software (ACS) provides the graphical user interface (GUI) for managing the resources in the system. This application runs on a Windows-based workstation that is equipped with a touch-screen or standard monitor, and control devices such as a keyboard, mouse and trackball.

FLEXIBLE SCREEN CONFIGURATIONS

Any number of screen configurations can be created and assigned to any position. This includes configurations to reflect available resources, dispatch functions, duty shifts and schedules, supervisory and maintenance roles, and training exercise simulations. For example, you might create a "location-based" resource configuration that uses icons overlaying graphic images to show the locations of resources such as radios, telephones, public address speakers and video cameras. This helps to ensure operational efficiency and reduces training for new dispatchers.

ACOM CONSOLE SOFTWARE AND SYSTEM TOOLS

Acom's log-on capabilities range from basic user screen startup to full, authenticated log-on control. Configurations can be assigned to operators automatically, based on their log-on profile, or they can be modified "on the fly," as circumstances warrant and permissions allow. In addition, supervisors can use network management resources to create, activate and publish configurations.

The ACS allows operators to make and receive telephone and radio calls and perform all the functions of a call. Operators can also use ACS to:

- View call queues and call history.
- Retrieve instant playback of conversations where an IRR is fitted.
- Patch and conference radios and telephone lines.
- Intelligently control radios.
- Simultaneously transmit to dissimilar radio types with a single press of the push-to-talk button.
- Interact simultaneously with multiple operators or callers.
- Use an embedded HTML/PDF browser to view procedures online.
- Link calls to procedures and activate them through HTML hyperlinks.



ACS configured with embedded browser



Location-based ACS configuration

ENSURING THAT YOUR SOLUTION MEETS YOUR OPERATIONAL NEEDS

If your specific functional requirement is not met by the standard functions Acom offers, Zetron's experienced personnel will work with you to devise a solution that does meet your needs.

INTEGRATED MANAGEMENT SYSTEM (IMS)

The Integrated Management System (IMS) is a Windows-based application that is used to configure, diagnose, and maintain the Acom system. The IMS is a map-based resource-management tool that allows system administrators and maintenance and support personnel (including Zetron technical support personnel) to view, assess and control system resources.

The IMS can access an Acom system either directly from a maintenance terminal or remotely through a network or dial-up connection. When an administrator clicks a particular network resource icon in the display, a visual representation of the resource appears. This allows the administrator to review or change the resource's configuration and status information.

CONSOLE DESIGN SOFTWARE

Acom's Console Design Software is a Windows-based application that is used to design and configure the Acom console interface screen. Because it is so flexible, it can accommodate almost any function, size, resource, appearance or location needed for a particular position.

The Console Design Software includes a simple, highly intuitive interface for screen creation and quick editing. It also includes all of the graphical design tools and editing functions necessary to create user interfaces and assign system resources to buttons and other screen elements such as icons and HTML links.

Acom's Console Design Software offers a wide range of functionality and capabilities, with screen layouts that can include icons and keys for accessing all communications resources, function controls, calling queues, information display areas and user databases. Screens can be configured to include a variety of user tools, such as list boxes, resource-based graphics, tabbed windows and Web browsers. Button labels, sizes, colors and fonts can all be changed. Icons can be added to the buttons as bitmaps to make the screen easier for operators to use.

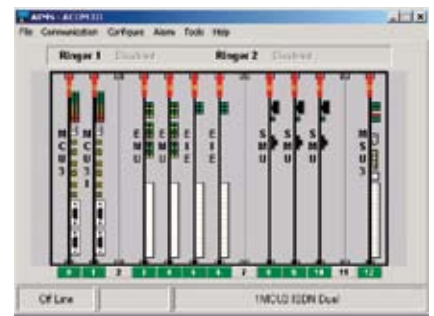

IMS ALS configuration display



IMS ACU configuration display

ACOM CONSOLE SOFTWARE OFFERS OPERATORS A WIDE RANGE OF PROGRAMMABLE FUNCTIONS

- | | | |
|---|--|---|
| <ul style="list-style-type: none"> ■ Radio and telephone queues with priority queuing ■ Radio/telephony patching and conferencing ■ Channel select ■ Call-history display ■ Working groups ■ Answer Next /Hold ■ Dial/Last Number Redial | <ul style="list-style-type: none"> ■ Memory/Speed Dial ■ Call Forward/Transfer ■ Mute/Clear ■ Transmit (PTT) ■ Transmit All ■ Instant Transmit ■ SELCAL/Tone control ■ Fully programmable paging | <ul style="list-style-type: none"> ■ Full-duplex, direct and addressable intercom ■ Foreground and background audio-level controls ■ Console resource indicators ■ Control of auxiliary relays (such as doors and alarms) ■ Utility audio (TV, commercial radio) |
|---|--|---|

NETWORK ARCHITECTURE

SYSTEM TOPOLOGY

The communications links for the Acom Console Unit (ACU) connect to form a self-healing loop. This creates redundant communication paths so that even if one unit in the loop fails, the system will continue to operate on the remaining console positions. Console positions can be connected locally to the switch, or they can be located remotely and connected back to the switch through a T1 or E1 link over either a direct wire-line connection or an IP network connection. Using specifically configured ACUs, single console positions can also be remotely located from the main switching site.

Each Acom Line Subrack (ALS) is connected to a single Acom DS3 Subrack (ADS). They are usually located together in an equipment room. This combination of ALS and ADS equipment is known as the Common Control Equipment (CCE). Multiple connected ALS units provide access to all of the radio, telephone and data resources the system requires. ALS equipment can be remotely located if required, and then connected back to the ADS through a T1 or E1 link over either a direct wire-line connection or an IP network connection.

Acom includes significant data switching and conferencing capabilities. Data can be switched between the data-channel interfaces, for example, with Acom simply serving as a multiplexer. Or it can be interpreted and manipulated by the ALS to control radios and other equipment.

Acom is ideal for switching or conferencing data as well as converting to protocols such as Voice-over-Internet Protocol (VoIP). In addition, Acom can provide native connections to digital radio networks. This eliminates audio quality problems that can arise with multiple analog-to-digital-to-analog conversions.

Acom can also be configured for full "hot-standby" redundancy. To achieve this, Acom changeover control equipment connects the primary and standby Acom systems to the external equipment. The alarm outputs on two interconnected Acom switch units control any changeover. A data link between the primary and standby systems allows for data "shadowing" between the two systems. This creates a true "hot-standby" architecture.

DISTRIBUTED SWITCHING

Acom is an ideal platform for creating and managing a network of dispatch facilities and sharing communications resources among them. Several of Acom's set-up capabilities are designed to provide the switching architecture that such a network requires.

For example, a high-bandwidth connection can be used to extend the backbone and create a seamless, non-blocking network that links multiple dispatch facilities and maximizes capacity. The networked system's Common Control Equipment (CCE) can either be consolidated at a single site or distributed among various sites in the network. Any site in the network can perform the dispatch functions of any other site. This provides the ultimate survivability and resiliency dispatch communications infrastructures require.

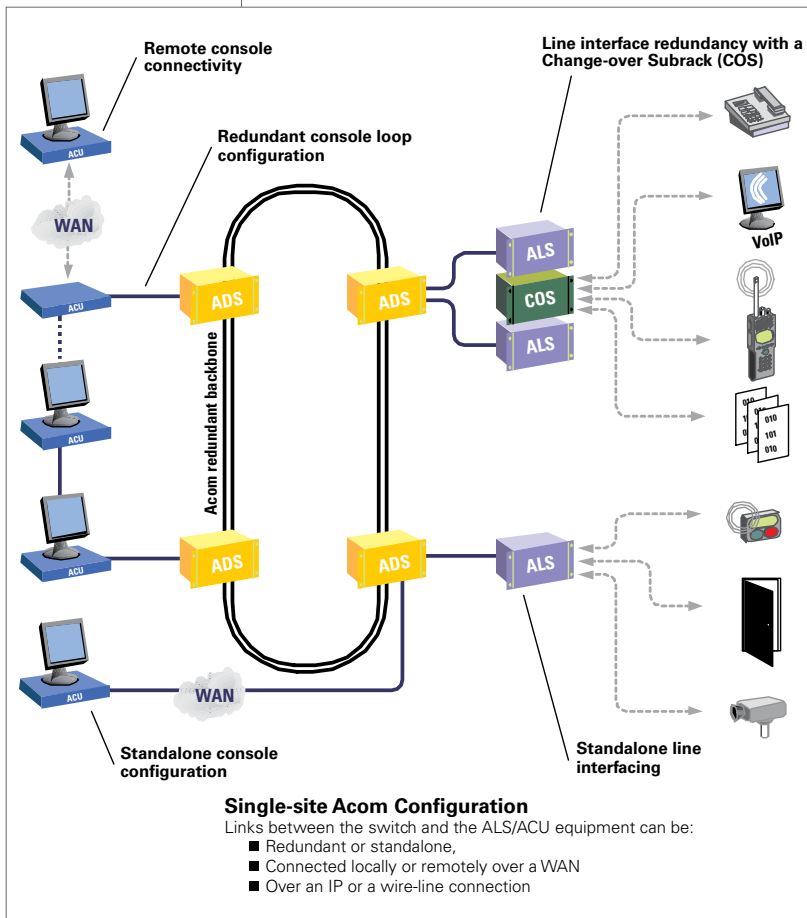

NETWORK ARCHITECTURE

Alternatively, sites that make up a multiple-dispatch facility—such as those that include a primary site and a remote, back-up site—can be linked through a high-bandwidth T1 or E1 link over either a direct wire-line connection or an IP network connection; or lower-bandwidth, leased-line connections, also known as intersite bearers.

A system that uses an intersite bearer is set up to share resources between sites, giving the system the functional aspects of a single Acom system distributed across multiple sites. This allows phone lines at one site to be used for both incoming and outgoing calls by operators at any other connected site. Remote lines can be included in conferences, working groups and patches as if they were local. Remote consoles can be accessed through the network's internal intercom functionality.

Intersite bearers can also be set up to allow each system to access another site, either directly or through any other site. Each site operates independently, with the interconnections providing necessary linkage to resources from other sites as required. This can be particularly useful for facilitating

communications among related but independent agencies, such as law enforcement, fire and EMS agencies within a single county, state or region.

FLEXIBLE CONFIGURATION

Acom architecture can be used to implement the core switching capabilities of the Common Control Equipment (CCE) anywhere in the network, including at the desktop itself. This offers many advantages. An Acom Console Unit (ACU)-based distributed switching architecture reduces the system's dependence on its CCE and thus enhances system integrity.

Acom's distributed switching environment also allows operators to move easily among positions and geographic locations. Wherever they are on the network, operators can log on to the Acom system and perform their functions as though they were seated at their own workstation.

In addition, although Acom's distributed switching offers many significant advantages, Acom can still be configured to accommodate organizations that prefer or require central switching.

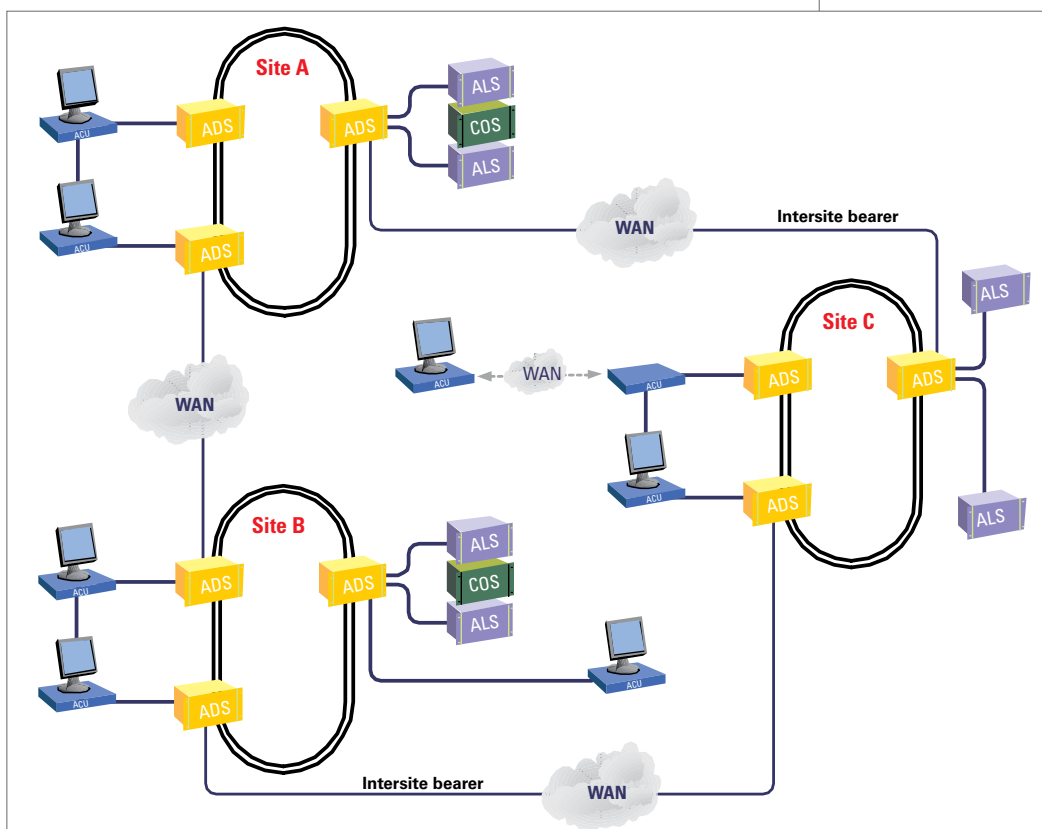

Multisite Acom Configuration

Links between the sites can be over an IP or a wire-line (E1/T1) connection

SECURITY : PUBLIC SAFETY : TRANSPORTATION : UTILITIES : FACILITIES SAFETY & SECURITY :

ZETRON USA

PO Box 97004
Redmond, WA
98073-9704
USA

TEL +1 425 820 6363

FAX +1 425 820 7031

zetron@zetron.com

ZETRON UK

27-29 Campbell Court
Bramley TADLEY
Basingstoke RG26 5EG
UK

TEL +44 (0)1256 880663

FAX +44 (0)1256 880491

uk@zetron.com

ZETRON AUSTRALASIA

PO Box 3045
Stafford Mail Centre
Stafford QLD 4053
Australia

TEL +61 7 3856 4888

FAX +61 7 3356 6877

ausales@zetron.com